



UNITED STATES AND CANADIAN
ACADEMY OF PATHOLOGY

Creating a Better Pathologist



USCAP 113TH ANNUAL MEETING

BRINGING EDUCATION TO LIFE

MARCH 23–28, 2024

BALTIMORE, MARYLAND
BALTIMORE CONVENTION CENTER, BALTIMORE, MD



SPONSOR AND EXHIBITOR INFORMATION

EXHIBIT DATES:
Monday, March 25
to Wednesday, March 27



MEETING DATES:
Saturday, March 23
to Thursday, March 28

THE USCAP ANNUAL MEETINGS CONTINUE TO SET RECORDS



The USCAP Annual Meeting has truly become pathology's global event. Decision makers in the field of pathology and the related specialties of molecular, toxicology, oncology, and immunology from hospitals, private laboratories, academic institutions, and the government will be in attendance. After an excellent meeting in New Orleans this past March, the Academy looks forward to setting new records for attendance and participating exhibitors in 2024 and beyond!

Exceptional opportunities at our 113th Annual Meeting include:

- Twenty-two hours of exhibit time take place over three days
- Coffee will be served only in the Exhibit Hall during dedicated morning and afternoon program breaks, including a Special Wednesday afternoon exhibit hall Closing Reception
- The highly-attended poster presentations are within the Exhibit Hall
- Exhibitors are invited to join the meeting's attendees at the **"USCAP Opening Reception"** party Saturday, March 23, 6–7:30 PM – great food and entertainment that you do not want to miss!
- Marketing opportunities have been expanded to meet every budget
- Increased visibility has been achieved through the following methods:
 - o Sponsor and Exhibitor listings on our meeting website (+8 million hits during the three months leading up to and during our meeting) and mobile app
 - o USCAP-generated emails sent to all registered attendees
 - o USCAP-generated social media posts to our followers

- Exhibitor and Sponsor registration is quick and easy
- USCAP plays an active role in supporting our partners' requirements to meet the Open Payments Program (Sunshine Act). To ensure this important requirement is met, USCAP is requesting each MD's National Provider Identifier (NPI number) during the registration process. It will be included in the badge bar code content which exhibitors are able to capture when they scan an attendee's badge.

With the continued growth of the USCAP Annual Meeting and exhibit floor, exhibitor space will sell out very quickly. Submit your application as soon as possible to ensure that you are able to secure space. To help you make your decision, please find the enclosed information regarding audience demographics, sponsorships, exhibitor rules, and the floor plan information to secure your participation, within this brochure. Whether you choose to become an exhibitor or a sponsoring exhibitor, you'll find many opportunities to promote your organization to pathology's global leaders.

The USCAP Annual Meeting has become pathology's must-attend event. Don't miss this extraordinary opportunity to meet the global pathology marketplace!

Kristofer S. Herlitz
The Herlitz Company
Exhibit Management

IMPORTANT DATES



OCTOBER 2023

- Sponsor and exhibitor brochure online Sponsorship sales begin
- Exhibit booth selection and payment opens
- Exhibition floor plan available online
- Exhibitor Seminars: Reservations open to secure space and date

NOVEMBER 2023

- Friday, November 17** – Priority point deadline (priority in space assignment accorded to previous exhibitors)
 - Deadline for Early Bird Pricing

DECEMBER 2023

- Friday, December 8** – Exhibitor Service Manual posted online for ordering
 - Booth assignments announced
- Friday, December 22** – Last date to cancel/ reduce booth space and receive 75% refund for booth space cost
 - Last date to cancel sponsorship commitment (minus a 20% administrative fee)

JANUARY 2024

- Friday, January 19** – Deadline for Ads/Sponsors Materials
- Thursday, January 25** – Last day to cancel/reduce booth space and receive 50% refund for booth space cost
 - Sponsorships Balance Due

FEBRUARY 2024

- Friday, February 2** – Exhibitor seminars: Deadline to apply and pay

IMPORTANT DATES

EXHIBITION HALL DATES

SETUP

March 22, 2024

1 PM to 4 PM

March 23, 2024

8:00 AM to 4:00 PM

March 24, 2024

8:00 AM to 4:00 PM

DAY 1

March 25, 2024

9:30 AM to 5:00 PM

DAY 2

March 26, 2024

9:30 AM to 5:00 PM

DAY 3

March 27, 2024

9:00 AM to 4:00 PM

TEARDOWN

March 27, 2024

4:00 PM to Midnight

March 28, 2024

8:00 AM to Noon

FEBRUARY 2024

Friday, February 20 – Earliest day to receive shipments at the Advanced Warehouse

– New Product Display materials due

– **Final booth payments due**

MARCH 2024

Friday, March 1 – Giveaway approval request form due

– Last day to submit booth schematics for approval

Tuesday, March 5 – Hotel reservations deadline (5:00 PM EST)

Friday, March 8 – Last day to submit EAC form and certificates of insurance

– Last day to use pre-registration mailing list (street addresses).

– Exhibitor badge names due

Monday, March 14 – Deadline for Innovative Expo receive materials at its Advance Warehouse

Friday, March 22 – Earliest day shipments may be received on-site by Innovative Expo

– Move in/exhibitor Installation 1:00 PM to 4:00 PM

Saturday, March 23 – Move in/exhibitor Installation 8:00 AM to 4:00 PM

Sunday, March 24 – Move in/exhibitor Installation 8:00 AM to 4:00 PM

Monday, March 25 – Exhibition Hall opens from 9:30 AM to 5:00 PM

Tuesday, March 26 – Exhibition Hall open from 9:30 AM to 5:00 PM

Wednesday, March 27 – Exhibition Hall open from 9:00 AM to 4:00 PM

– Exhibit Hall Closing Reception 2:30 PM-4:00 PM

– Exhibition Hall closes at 4:00 PM

– Exhibitor dismantling/move out 4:00 PM to Midnight

Thursday, March 28 – Exhibitor dismantling/move out 8:00 AM to Noon

CONTACTS

EXHIBITOR AND SPONSORSHIP INFORMATION

Kristofer S. Herlitz
The Herlitz Company
108 Montgomery Street, Suite 205
Rhinebeck, NY 12572-1106
Email: kris@herlitz.com
Phone: 845.243.2906

SHOW DECORATORS

Jeff Trofholz
Innovative Expo
72242 Watt Court
Thousand Palms, CA 92276
Email: service@innovativeexpo.com
Phone: 760.343.2555
Fax: 760.343.2533

EXHIBITOR SEMINARS

Kristofer S. Herlitz
The Herlitz Company
108 Montgomery Street, Suite 205
Rhinebeck, NY 12572-1106
Email: kris@herlitz.com
Phone: 845.243.2906

PRESS

Lisa Olson
USCAP
201 N. Palm Canyon Drive
Suite 301
Palm Springs, CA 92262
Email: press@uscap.org
Phone: 760.327.6777
Fax: 760.327.6477

USCAP'S MODERN PATHOLOGY AND LABORATORY INVESTIGATION ADVERTISING

Jim Secretario
US Sales Director
(US and Canada)
Phone: 917.678.0541
E-mail: j.secretario@elsevier.com

Robert Bayliss
Head of Sales - Europe (EU
Territory and ROW)
Phone: + 44 20 7424 4454
E-mail: r.bayliss@elsevier.com

IMPORTANT LINKS

Exhibit Floor Plan:

<https://s36.a2zinc.net/clients/aimusa/uscap2024/Public/EventMap.aspx?shMode=E>

Application for Exhibitors:

https://s36.a2zinc.net/clients/aimusa/uscap2024/Public/e_login.aspx?frompage=e_BoothSales

Sponsorship Gallery:

<https://s36.a2zinc.net/clients/aimusa/uscap2024/Public/sponsorshipgallery.aspx?ID=977>

QUICK REFERENCE

Important Dates	2	Sponsorship Opportunities	9
Booth Pricing	20	Sponsorship Application	16
Helpful Contact Information	4	Rules and Regulations	18
Included with Your Booth Space	23	Exhibit Floor Meeting Rooms Information	41
2023 Annual Meeting Exhibitors	7	Exhibitor Seminars Information	42
Exhibit Hall Floor Plan	24		

QUICK REFERENCE: 2023 ANNUAL MEETING STATS

2023 MEETING ATTENDEES: TOTAL 4,637

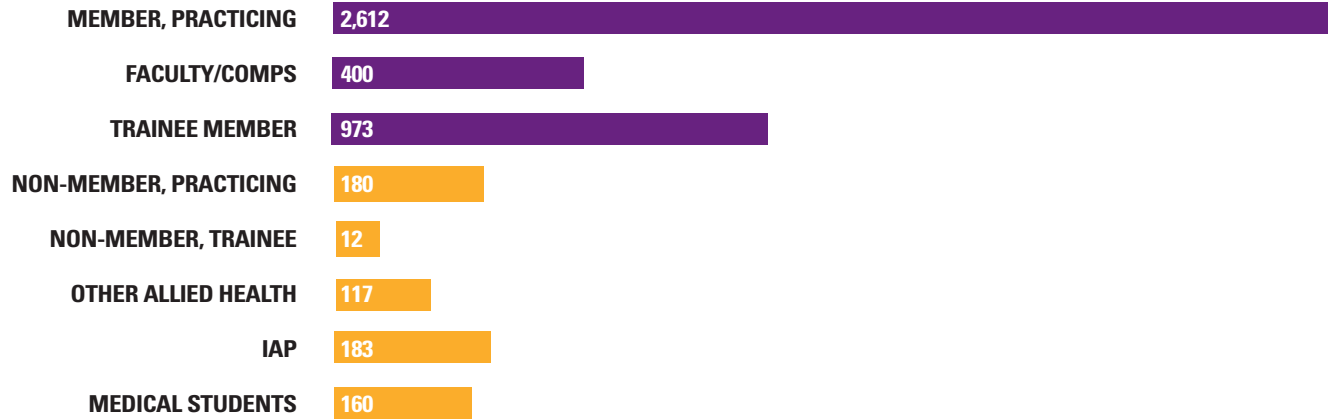

REGISTRANTS BY SUBSPECIALTY

Autopsy	19
Blood Banking/Transfusion Medicine	5
Bone and Soft Tissue Pathology	140
Breast Pathology	323
Cardiovascular Pathology	41
Chemical Pathology	2
Cytopathology	314
Dermatopathology	167
Education	22
Endocrine Pathology	40
Forensic Pathology	33
Gastrointestinal Pathology	456
General Surgical Pathology	429
Genitourinary Pathology	289
Gynecologic Pathology	315
Head and Neck Pathology	140
Hematopathology	432
Infectious Disease Pathology	18
Informatics	55
Kidney/Renal Pathology	111
Liver Pathology	67
Medical Microbiology	6
Molecular/Genetic Pathology	148
Neuropathology	103
None Apply	543
Ophthalmic Pathology	10
Other Pathology	101
Pancreas and Biliary Tree Pathology	21
Pathobiology	23
Pediatric Pathology	83
Perinatal and Postnatal Path	5
Pulmonary Pathology	106
Quality Assurance	6
Techniques	18
Thoracic Pathology	43
Ultrastructural Pathology	3
TOTAL	4,637

NATIONALITY

International Attendees	1,252
Countries	88

TOP 10 COUNTRIES

Australia	126	China	64
United Kingdom	90	South Korea	55
Brazil	67	Spain	55
Germany	67	Italy	48
Japan	66	Switzerland	45

36 COMPANION MEETINGS

84 SHORT COURSES

2,492 SCIENTIFIC ABSTRACTS
1,694 ACCEPTED

70 INTERACTIVE MICROSCOPY
COURSES

18 EVENING SPECIALTY
CONFERENCES

36 COMPANION SOCIETY MEETINGS ARE HELD IN CONJUNCTION WITH THE USCAP ANNUAL MEETING

American Association for Cancer Research
American Association of Neuropathologists
American Association of Ophthalmic Oncologists and Pathologists
American Society for Clinical Pathology
American Society for Investigative Pathology
American Society of Cytopathology
American Society of Dermatopathology
Arthur Purdy Stout Society of Surgical Pathologists
Association for Molecular Pathology
Association for Pathology Informatics
Binford-Dammin Society of Infectious Disease Pathologists
Chinese American Pathologists Association
Chinese Society of Pathology
College of American Pathologists
Endocrine Pathology Society
European Society of Pathology
Genitourinary Pathology Society
Hans Popper Hepatopathology Society
History of Pathology Society
International Academy of Cytology
International Society of Bone & Soft Tissue Pathology
International Society of Breast Pathology
International Society of Gynecological Pathologists
International Society of Urological Pathology
National Association of Medical Examiners
North American Society for Head and Neck Pathology
Pakistani-American Pathologists' Society
Paleopathology Club
Pancreatobiliary Pathology Society
Papanicolaou Society of Cytopathology
Pulmonary Pathology Society
Renal Pathology Society
Rodger C. Haggitt Gastrointestinal Pathology Society
Society for Cardiovascular Pathology
Society for Hematopathology
Society for Ultrastructural Pathology

2023 ANNUAL MEETING EXHIBITORS + SPONSORS

GOLD



abbvie



SILVER



COMPANY

35th Congress of the European Society of Pathology

3DHISTECH Ltd.

AbbVie

ACCU-SCOPE Inc.

Ace My Path

Advanced Cell Diagnostics

Agilent/Dako

Aiforia, Inc

AIRA Matrix Private Limited

AlxMed, Inc.

American Association of Pathologists' Assistants (AAPA)

American Board of Pathology

American Society for Clinical Pathology ASCP

American Society of Cytopathology (ASC)

Anatomical Pathology Patient Interest Association (APPIA)

Anchor Molecular Inc.

Apollo Enterprise Imaging Corp

Applied Spectral Imaging

Arima Genomics

ARP Press

Association for Molecular Pathology

Astellas Pharma

AstraZeneca Precision Medicine

Barco, Inc.

Beijing Thorough Future Technology Co., Ltd

Bio SB, Inc

Biocare Medical

Biocartis US

Biofidelity

Biogenex

Biomiga, Inc.

BioView, Inc.

Blueprint Medicines

Boston Cell Standards

BostonGene

Bradley Products, Inc.

Bristol-Myers Squibb

Cancer Diagnostics, Inc.

Caris Life Sciences

Castle Biosciences

CELNOVTE BIO-TECH CO.,LTD

Change Healthcare

Charity Project

Clarix Imaging

Cleveland Clinic Laboratories

College of American Pathologists

Corista

Dakewe US

Deciphex

Deep Bio Inc.

DeePathology Ltd.

Delong America

Digital Pathology Association (DPA)

DigitCells

Dolbey

DREAMPATH

Eli Lilly and Company

ELITechGroup

ELSEVIER

Epredia

Evident Scientific

Exact Sciences

FormaPath

Foundation Medicine, Inc.

FUJIFILM Healthcare Americas Corporation

GA International

Genentech, Inc.

COMPANY

General Data Healthcare
Genomic Testing Cooperative
Gestalt Diagnostics
GoPath Diagnostics
Grundium
Guangzhou Labsim Biotech Co., Ltd.
Hamamatsu Corporation
Hangzhou Bailing Biotechnology Co., Ltd.
Headshot Lounge
Heidstar Co. , Ltd.
Hologic, Inc.
Huron Digital Pathology
IAP - Mexican Division
Ibex Medical Analytics
Indica Labs
INFINITT North America
Innovative Science Press
Institute of Pathology
International Academy of Cytology, The
International Academy of Pathology
iProcess Global Research Inc
Iron Mountain
ISENET-USA, LLC
KFBIO
Leica Biosystems
LUMEA
Luminos Pro
Merck & Co., Inc.
Merus NV
MetaSystems Group, Inc.
Michigan Medicine Laboratories (MLabs)
Mikroscan Technologies, Inc.
Milestone Medical
MilliporeSigma / Cell Marque
Mindpeak GmbH
Molecular Instruments
Morphle Labs Inc.
Motic Digital Pathology
MphaR (Medical Pharma Services)
MS Validated Antibodies
NeoGenomics Laboratories
Nikon Instruments Inc.
Novartis Pharmaceuticals
Novodiox
NovoPath
Objective Imaging Inc
OpraSCAN, Inc.
Orchard Software Corporation
Owkin
PAIGE
PathAI
PathologyOutlines.com
PathPresenter
Philips Digital Pathology Solutions
Pramana
Precipio
PeciPoint
Precisionary Instruments LLC
PRIME INSTRUMENTS CORP
Primera Technology
Proscia Inc
Qritive
RedRick Technologies Inc.
Remote Medical Technologies
Roche Diagnostics Corporation
RWD Life Science Co., LTD
Sakura Finetek USA, Inc.
Sanofi
Scopio Labs
Seagen
Sectra
Shanghai DaoChang Medical Sci-Tech Co., Ltd.
Siemens Healthineers
Sonic Healthcare USA
Splintellx, Inc.
SPOT Imaging
Springer Nature
Stanford Health Care
StatLab Medical Products
Stemline Therapeutics
Takeda
Techcyte
Ted Pella, Inc.
Teledyne Lumenera
Tempus
Texere Publishing Limited
Thermo Fisher Scientific
Tribun Health
United States and Canadian Academy of Pathology
University of Miami
Vanderbilt Pathology Laboratory Services
Vector Surgical, LLC
ViraSoft Inc.
Visiopharm A/S
Voicebrook
Wolters Kluwer
World Health Organization - WHO Press
Wuhan Landing Intelligence Medical Co., Ltd
XIFIN, Inc.
Yale Pathology Lab
Zeta Corporation

2024 SPONSORSHIP OPPORTUNITIES: MAJOR SPONSORS

PLATINUM SPONSORS – \$60,000

ON-SITE VISIBILITY

- **Three (3) exhibit booths** (additional booths at \$3,300 each; \$3,600 corner booth; \$4,200 island booth) with priority placement in the Exhibit Hall.
- **SPONSORS' VIP LOUNGE!** Platinum level access; naming and appreciation signage.
- **Co-Sponsorship of "USCAP Opening Reception."** Take advantage of this exclusive opportunity to have your branding alongside of the Academy's at THE SOCIAL EVENT of the Annual Meeting held on Saturday, March 23rd from 6-7:30 PM.
- **USCAP LEADERSHIP Sponsors' Booths Tour** – prior to the Ribbon Cutting for the official opening of the USCAP 2024 exhibits, Academy leadership will do a walk-through visiting Sponsors' booths.
- **Complimentary Lead Retrieval System** (up to 10 licenses).
- **Connect Lounge** – The Connect Lounge is all about bringing people together. A place where registrants can check their emails and relax between sessions or meet up with your peers with real, unplugged conversations.
- **Eighteen (18) exhibit badges** with Platinum Sponsorship ribbon for booth representatives.
- **One (1) full meeting registration**
- **Choice of one:** sponsorship of (1) **USCAP Trainee Mixer**, or (1) **Coffee Break in the Exhibit Hall**, or (1) **Speaker Ready Room**.
- **Access to the USCAP mailing list** for one mailing.
- **One email to USCAP Registrants**
- **Two invitations to the USCAP President's Reception.**
- **Prominent listing as a Platinum Sponsor** with logo on Entrance Unit of the Exhibit Hall.
- **Identified as an official USCAP Platinum Sponsor** in the 2024 USCAP Annual Meeting communications and right to use the 2024 USCAP Annual Meeting sponsor logo in electronic advertisements and promos.
- **Purchase additional sponsorship items with a 10% discount** on the purchase of one or more items.

DIGITAL VISIBILITY/OTHER MEDIA

- **Full color ad on the footer of the Popular Digital Exhibit Hall Locator Touch screens** used by attendees to view and search the Interactive Exhibitor Floor Plan by company name as well as products/services.
- **Ten-second company video** (no audio permitted) running 3x per cycle on all Meeting Monitors (65") strategically placed throughout the Convention Center to maximize exposure and giving your company the benefit of increased visibility outside of the exhibit hall.
- **Prominent placement in "Thank You, Sponsors" ads** in on-site Meeting banner and scrolling Monitors.
- **Highlighted listing on the dedicated Sponsors button on the Popular Digital Exhibit Hall Locator Touch screens.**
- **Prominent placement with links in the 2024 USCAP Annual Meeting's meeting e-blasts.**
- **Logo on the USCAP website** with a link to your homepage (our website receives more than 8 million hits per month in the months leading up to, during, and after the Annual Meeting).

2024 SPONSORSHIP OPPORTUNITIES: MAJOR SPONSORS

ENHANCED ONLINE EXHIBITOR LISTING TO INCLUDE:

- **Online Profile**—Update your booth profile with all relevant company information (1,000 characters).
- **Welcome Message**—Add an event-specific message to highlight your presence at the meeting.
- **Videos**—Let potential buyers see and hear your story through up to two promotional videos.
- **Product Categories**—Select up to 10 categories to help your customers find you faster!
- **Products**—Feature up to 10 of your product lines or some of your most popular brands, including text descriptions and photos.
- **Press Releases**—Highlight up to 10 of your company’s releases. Tell your story in a printable, downloadable press release. These will also be cataloged with several major search engines.
- **Show Specials**—Spotlight up to 10 deals, discounts, giveaways, post-show drawings, and so on, to keep the traffic coming to your booth.
- **Event Map Logo**—Brand your presence on the show floor to make your company stand out.
- **Enhanced Online Display Listing**—Help your company stand out! As a sponsor, your listing will be highlighted to ensure all of our attendees know of your support of USCAP.

Deadlines for ads: final sponsor information must be received by the USCAP by Friday, January 19, 2024

GOLD SPONSORS – \$30,000

ON-SITE VISIBILITY

- **Two (2) exhibit booths** (additional booths at \$3,300 each; \$3,600 corner booth; \$4,200 island booth).
- **SPONSORS' VIP LOUNGE!** Gold level access; naming and appreciation signage.
- **USCAP LEADERSHIP Sponsors' Booths Tour** – prior to the Ribbon Cutting for the official opening of the exhibits, USCAP leadership will do a walk-through visiting Sponsors' booths.
- **Complimentary Lead Retrieval System** (up to 10 licenses).
- **Twelve (12) exhibit badges** with Gold Sponsorship ribbon for booth representatives.
- **Choice of one: sponsorship of (1) Fellowship Fair OR (1) Charging Station AND (1) Coffee Break** in the Exhibit Hall.
- **Access to the USCAP mailing list** for one mailing.
- **One email to USCAP Registrants.**
- **Prominent listing as a Gold Sponsor** with logo on Entrance Unit of the Exhibit Hall.
- **Identified as an official USCAP Gold Sponsor** in the 2024 USCAP Annual Meeting communications and right to use the 2024 USCAP Annual Meeting sponsor logo in electronic advertisements and promos.
- **Priority to purchase additional sponsorship items** with a 10% discount off the purchase of one or more items.

DIGITAL VISIBILITY/OTHER MEDIA

- **Full color ad on the footer of the Popular Digital Exhibit Hall Locator Touchscreens** used by attendees to view and search the Interactive Exhibitor Floor Plan by company name as well as products/services.
- **Ten-second company video** (no audio permitted) running 2x per cycle on all Meeting Monitors (65") strategically placed throughout the Convention Center to maximize exposure and giving your company the benefit of increased visibility outside of the exhibit hall.
- **Prominent placement in "Thank You, Sponsors" ads** on on-site Meeting banner and scrolling Monitors.
- **Listing on the dedicated Sponsors button on the Popular Digital Exhibit Hall Locator Touchscreens.**
- **Prominent placement with links in the 2024 USCAP Annual Meeting's meeting e-blasts.**
- **Logo on the USCAP website** with a link to your homepage (our website receives more than 8 million hits per month in the months leading up to, during and after the Annual Meeting).

ENHANCED ONLINE EXHIBITOR LISTING TO INCLUDE:

- **Online Profile**—Update your booth profile with all relevant company information (1,000 characters).
- **Welcome Message**—Add an event-specific message to highlight your presence at the meeting.
- **Video**—Let potential buyers see and hear your story through a promotional video.
- **Product Categories**—Select up to five categories to help your customers find you faster!
- **Products**—Feature up to five of your product lines or your most popular brands, including text descriptions and photos.
- **Press Releases**—Highlight up to five of your company's releases. Tell your story in a printable, downloadable press release. These will also be cataloged with several major search engines.
- **Show Specials**—Spotlight up to five deals, discounts, giveaways, post-show drawings, and so on, to keep the traffic coming to your booth.
- **Event Map Logo**—Brand your presence on the show floor to make your company stand out.
- **Enhanced Online Display Listing**—Help your company stand out! As a sponsor, your listing will be highlighted to ensure all of our attendees know of your support of USCAP.

Deadlines for ads: final sponsor information must be received by the USCAP by Friday, January 19, 2024

SILVER SPONSORS—\$20,000

ON-SITE VISIBILITY

- **One corner booth** (additional booths at \$3,300 each; \$3,600 corner booth; \$4,200 island booth).
- **SPONSORS' VIP LOUNGE!** Silver level access and appreciation signage.
- **USCAP LEADERSHIP Sponsors' Booths Tour** – prior to the Ribbon Cutting for the official opening of the exhibits, USCAP leadership will do a walk-through visiting Sponsors' booths.
- **Complimentary Lead Retrieval System (up to 10 licenses).**
- **Six exhibitor badges** with Silver Sponsorship ribbon for booth representatives.
- **Choice of one: sponsorship** of (1) **USCAP Trainee Mixer**, or (1) **Coffee Break** in the Exhibit Hall, or (1) **Mentors at the Table**.
- **Access to the USCAP mailing list** for one mailing.
- **Prominent listing as a Silver Sponsor** with logo on Entrance Unit of the Exhibit Hall.
- **Identified as an official USCAP Silver Sponsor** in the 2024 USCAP Annual Meeting communications and right to use the 2024 USCAP Annual Meeting sponsor logo in electronic advertisements and promos.
- **Priority to purchase additional sponsorship items** with a 10% discount off the purchase of one or more items.

DIGITAL VISIBILITY/OTHER MEDIA

- **Full color ad on the footer of the Popular Digital Exhibit Hall Locator Touchscreens** used by attendees to view and search the Interactive Exhibitor Floor Plan by company name as well as products/services.
- **Ten-second company video** (no audio permitted) running 1x per cycle on all Meeting Monitors (65") strategically placed throughout the Convention Center to maximize exposure and giving your company the benefit of increased visibility outside of the exhibit hall.
- **Prominent placement in "Thank You, Sponsors" ads** on on-site Meeting banner and scrolling Monitors.
- **Listing on the dedicated Sponsors button on the Popular Digital Exhibit Hall Locator Touchscreens.**
- **Prominent placement with links in the 2024 USCAP Annual Meeting's meeting e-blasts**
- **Logo on the USCAP website** with a link to your homepage (our website receives more than 8 million hits per month in the months leading up to, during and after the Annual Meeting).

ENHANCED ONLINE EXHIBITOR LISTING TO INCLUDE:

- **Online Profile**—Update your booth profile with all relevant company information (750 characters).
- **Welcome Message**—Add an event-specific message to highlight your presence at the meeting.
- **Product Categories**—Select up to five categories to help your customers find you faster!
- **Products**—Feature a product line or your most popular brand, including text descriptions and photos
- **Press Releases**—Highlight one of your company's releases. Tell your story in a printable, downloadable press release. These will also be cataloged with several major search engines.
- **Show Specials**—Spotlight one deal, discount, giveaway, post-show drawing, and so on, to keep the traffic coming to your booth.
- **Event Map Logo**—Brand your presence on the show floor to make your company stand out.
- **Enhanced Online Display Listing**—Help your company stand out! As a sponsor, your listing will be highlighted to ensure all of our attendees know of your support of the USCAP.

Deadlines for ads: final sponsor information must be received by the USCAP by Friday, January 19, 2024



ADDITIONAL SPONSORSHIP OPPORTUNITIES

USCAP Opening Reception! – \$50,000 Exclusive Sponsor (first to reserve) OR \$15,000 Co-Sponsor (limited to first 3 exhibitors to reserve)

Show your support of the Academy’s Signature Event! With a perennial attendance of over 2,000 people, this is easily THE SOCIAL EVENT of the Annual Meeting - **The USCAP Opening Reception** is where attendees and exhibitors gather together in a both relaxed and exciting atmosphere. Partake in the amazing Food and Drink while experiencing the lively Entertainment all with a local twist. Get in front of your audience at the “Scene to be Seen at” on Saturday from 6 PM–7:30 PM! Conveniently located at the Baltimore Hilton Inner Harbor headquarters hotel across from the Baltimore Convention Center.

Sponsors will be recognized on Signage throughout the space, as well as recognition on the USCAP website. Available to a single or multiple sponsors (limited to 3).

LANYARDS AND BADGES – \$20,000

The conference lanyards are available for sponsorship and provide a visible presence throughout the meeting. For 2024, we are using a full color printing with sponsor’s logo alternating with the USCAP logo. This prime real estate ensures a consistent presence throughout the six-day event. The sponsor’s logo will be on each badge as well.

HOTEL ROOM KEY CARDS – \$15,000

Put your company’s name in the hand of every USCAP attendee staying at the Baltimore Inner Harbor headquarters hotel. Sponsor’s information will appear on our attendees’ room keys.

HOTEL ROOM KEY CARD SLEEVES – \$7,500

Insert your brand into the hand of every USCAP attendee staying at the Baltimore Inner Harbor headquarters hotel. Sponsor’s information will appear on our attendees’ room key sleeves.

AISLE SIGNS – \$15,000

Put your branding in every Aisle! Your company name and branding will be hung under every aisle sign. *Design/color scheme subject to USCAP approval based on show branding.

WI-FI SPONSORSHIP – \$15,000

Basic Wi-Fi will be available in the Exhibit Hall and all the meeting rooms; all USCAP attendees will have access to the network and your company will be noted as the WiFi Sponsor on the back of every badge where the Network name and Password are indicated. PLUS!! Your company’s booth will include one complimentary HOT SPOT including a high-speed wired Internet connection (up to 5 devices).

CONNECT LOUNGE – \$10,000

The Connect Lounge is all about bringing people together. A place where attendees can check their emails and relax between sessions or meet up with their peers with real, unplugged conversations.

HYDRATION STATIONS - \$10,000

Your company messaging will be placed at each of the USCAP 2024 water re-filling stations located throughout the Baltimore Convention Center.

USCAP MEETING APP (LIMIT 2) – \$7,500 EACH

This mobile app will keep attendees informed and engaged during the entire meeting. Meeting highlights, including the schedule, exhibitor list, and session information, will be readily available—and your company logo can be there too! Limited to two sponsors. Your logo will be prominently displayed on the USCAP Meeting App homepage and on meeting signage.

FELLOWSHIP FAIR – \$6,000

The most popular event with residents and faculty, this job fair attracts over 40 medical institutions and over 500 residents in a casual atmosphere. Soft drinks and water are provided. Sponsors receive recognition on signage at the event. Available to multiple sponsors.

HEADSHOT LOUNGE – \$5,000

This space is a flurry of activity with attendees coming and going getting their professional headshots taken (over 250 headshots taken in 2023!) or waiting to be taken. Capture their attention while they are there with your company's branding well represented in this island lounge both on overhead and in-booth signage.

CHARGING STATIONS (LIMIT 2) – \$5,000 PER STATION

Be noticed as attendees are charging up for the day. These stations simultaneously charge all types of cell phones and other handheld electronics and will be placed strategically for maximum exposure in the Baltimore Convention Center.

SPEAKER READY ROOM – \$5,500

These are your thought leaders and they ALL come here to prepare! Put Your Company Name in front of them with this coveted sponsorship. Sponsors receive recognition on the event signage.

USCAP TRAINEE MIXER – \$5,500

This reception is a great opportunity to get your name out to up-and-coming pathologists. Sponsors will receive recognition on event signage.

MENTORS AT THE TABLE – \$5,500

THE spot for residents to interact with pathology leaders, this is a wonderful opportunity to promote your selves to tomorrow's leaders. This locale is highly popular with the residents. Sponsors receive recognition on the event signage.

FLOOR CLINGS – \$5,000 (Limited to 2 Exhibitors)

Guide the attendees to your booth - step by step! These large 3' x 3' Floor Clings will not only get you noticed but will lead them right to you!

WEDNESDAY AFTERNOON EXHIBITS CLOSING RECEPTION – \$7,500 (Limited to 2 Exhibitors)

YOUR TICKET TO SUCCESS - BACK AGAIN THIS YEAR! The Wednesday exhibit hall closing reception will be the final surge - attendees can come to the sponsors' booth during the reception in order to request an additional drink ticket from your booth staff! **A closing cocktail reception with light snacks in the exhibit hall - and you have the drink tickets!** This will be the only Break advertised and promoted to the attendees to include a Bar and Snacks. Align your company with that distinction and appreciation! Put out your company branded napkins; get creative! Sponsors will also receive recognition on the break promotion and event signage.

HAND SANITIZER STATIONS (Includes 10 stations) – \$3,500 (Limited to 2 Exhibitors)

These stations are conveniently located throughout the convention center and will keep your company name associated with all those providing a "Helping Hand!"

COFFEE BREAKS (EACH) – \$4,000

Coffee breaks are provided in the Exhibit Hall Monday through Wednesday and at highly trafficked areas throughout the venue on days when the Exhibit Hall is closed. It's a perfect opportunity for quick meet- and-greets; put out your company branded napkins; get creative!. Sponsors will receive recognition on the event signage.

DIGITAL AD RETARGETING – \$3,000, \$6,000

\$3,000 Broad Interest Group - USCAP2023 attendees and consumers of courses and products

\$6,000 Elite Group - USCAP2023 and USCAP2024 registration page registrants and visitors.

LOGO ON BASE OF THE DIGITAL EXHIBITOR LOCATOR TOUCHSCREENS – \$2,000 (per station)

Place your company logo on large station base to the Digital Exhibitor Locator Touchscreens that are used by attendees to view, search, and navigate the Interactive Exhibitor Floor Plan by company name as well as by products and services.

OTHER OPPORTUNITIES including COLUMN WRAPS, ONSITE BADGE PICK-UP KIOSKS, CONVENTION CENTER CLINGS, AND MORE...

For more information about these sponsorship opportunities, please contact:

Kristofer S. Herlitz

The Herlitz Company

108 Montgomery Street, Suite 205
Rhinebeck, NY 12572-1106

Phone: 845.243.2906

Email: kris@herlitz.com

SPONSORSHIP APPLICATION

PLEASE CHECK ALL OF THE SPONSORSHIP OPPORTUNITIES IN WHICH YOU ARE INTERESTED.

Yes! Reserve this sponsorship for me!

	Costs	Quantity	Total Costs
PLATINUM SPONSOR	\$60,000		
GOLD SPONSOR	\$30,000		
SILVER SPONSOR	\$20,000		
USCAP CARNIVAL!	\$50,000 Exclusive or \$15,000 Co-Sponsor (limited to 3)		
Hydration Stations	\$10,000		
Lanyards and Badges	\$20,000		
Wi Fi Sponsorship	\$15,000		
Hotel Room Key Cards	\$15,000		
Aisle Signs	\$15,000		
Connect Lounge	\$10,000		
USCAP Meeting App (Limit 2)	\$7,500		
Hotel Room Key Card Sleeves	\$7,500		
Charging Stations (Limit 2)	\$5,000 (per station)		
Floor Clings	\$5,000		
Wednesday Afternoon Exhibits Closing Reception	\$7,500 (limited to 2 Exhibitors)		
Fellowship Fair	\$6,000		
Speaker Ready Room	\$5,500		
USCAP Trainee Mixer	\$5,500		
Mentors at the Table	\$5,500		
Headshot Lounge	\$5,000		
Coffee Breaks (each)	\$4,000		
Hand Sanitizer Stations	\$3,500 (includes 10 stations, limited to 2 Exhibitors)		
Digital Ad Retargeting	\$3,000 Broad Interest or \$6,000 Elite Group		
Logo on Base of Exhibitor Locator Touchscreens	\$2,000 (each)		

TOTAL COSTS

YOU MUST BE AN EXHIBITOR TO SPONSOR AN ITEM OR EVENT.

For exhibitor information, contact: Kristofer Herlitz at **845.243.2906**
or kris@herlitz.com

METHOD OF PAYMENT (CHECK ONE):

Check (payable to United States & Canadian Academy of Pathology – U.S. currency drawn on U.S. bank)

Credit Card - use **Exhibitor Portal** or call **Exhibit Management at 845.243.2906**

Pay online at Exhibitor Portal [here](#)

PLEASE PRINT CONTACT INFORMATION

Company Name: Contact:

Address:

City: State: Postal Code:

Country: Phone:

Email: Website:

SPONSORSHIP POLICY AND FEES

Payment Schedule

- A deposit of 50% must accompany the Sponsorship Form
- Balance due by January 25, 2024

This completed sponsor form and all payments should be sent to:

Kristofer Herlitz
108 Montgomery Street, Suite 205
Rhinebeck, NY 12572-1106

SPONSORSHIP CANCELLATION POLICY AND FEES

Cancellations must be made in writing to: **Kristofer Herlitz, 108 Montgomery Street, Suite 205, Rhinebeck, NY 12572-1106**, and must be received by the date listed below. Cancellations will be based on the following schedule:

- Until December 22, 2023, all commitments may be canceled in full, minus a 20% Administration fee based on the payments received to date
- Following the schedule of payments, any payments made after December 22, 2023, will not be refunded

EXHIBITOR INTERNAL COMPANY MEETINGS

Exhibitors may hold company meetings at any time provided that their booth is staffed and no professional registrants are in attendance. Exhibitors must confirm in writing, to the Academy, that the meeting is for company personnel only and no products will be displayed. Demonstrations and/or displays of commercial products and/or literature are not permitted.

Company meeting organizers will be responsible for establishing direct bill accounts directly with the facility in which their meeting is held.

Meeting space is limited in the Hilton Baltimore Inner Harbor. Requests for meeting space may only be submitted via the request form. You must complete a separate, individual form for each event to be held. Meeting space will be assigned on a first-come, first-served basis, in the order of date received. Receipt of your request by the Academy does not guarantee space assignment.

Room Charge: The Academy will provide rooms when possible for a room charge of \$500 per day, per room.

Signs for company meetings may only be placed outside the door entrance to the meeting. Directional signage for meetings is prohibited. Meeting organizers are responsible for removing signage and meeting handouts, etc., from their assigned rooms at the conclusion of the meeting.

CANCELLATIONS: If an exhibitor cancels their exhibit space, they will automatically lose the opportunity to use any approved meeting or special function rooms.

PLEASE CONTACT:

Stacie Hargett

USCAP

201 N. Palm Canyon Drive

Suite 301

Palm Springs, CA 92262

Email: stacie@uscap.org

Phone: 760.327.6777

Fax: 760.327.6477

RULES AND REGULATIONS FOR EXHIBITING AT THE 113TH USCAP ANNUAL MEETING



Please read the following Rules and Regulations (“Rules”) carefully. By submitting an application for exhibit space ([CLICK HERE](#)) for the event described on the first page herein, you, as agent for the exhibiting company (the “Exhibitor”), agree that you have the authority to bind the Exhibitor to these Rules and that the Exhibitor agrees to follow and be bound by the Rules. These Rules form a contractual relationship between Exhibitor and The United States and Canadian Academy of Pathology, Inc. (“USCAP” or “Academy”). Exhibitors accept responsibility for informing all of their employees and agents of these conditions and agree that they will abide by them.

SPACE ASSIGNMENT & FEES PRESENTATION OF PRODUCTS OR SERVICES

The purpose of the USCAP exhibit program is to further the education of the registrants by providing an area for Exhibitors to present information on products or services pertinent to the physician’s professional interests.

EXHIBIT HOURS AND DATES:

MONDAY, MARCH 25, 2024 | 9:30 AM–5:00 PM

TUESDAY, MARCH 26, 2024 | 9:30 AM–5:00 PM

WEDNESDAY, MARCH 27, 2024 | 9:00 AM–4:00 PM

EXHIBIT BOOTH MUST BE STAFFED AT ALL TIMES DURING EXHIBIT HOURS.

Exhibitors are advised to be in their booths one half-hour prior to show opening each day.

SCHEDULED COFFEE BREAKS:

MONDAY: 9:30 AM | 11:00 AM; 3:00 PM–4:30 PM

TUESDAY: 9:30 AM | 11:00 AM; 3:00 PM –4:30 PM

WEDNESDAY: 9:30 AM | 11:00 AM; 2:30 PM–4:00 PM

As a courtesy to the scientists and your fellow Exhibitors, USCAP requests strict adherence to the opening and closing hours. Deliveries or removal of equipment must be made before or after exhibit hours. A pass must be obtained from the Exhibit Management desk to remove any material or equipment prior to Wednesday, March 27, 2024. Once the exhibit opens for the last day of exhibiting, nothing may be removed until the exhibit is officially closed at 4:00 PM, at which time no pass is required. Security will not check equipment leaving the exhibit area after 4:00 PM, Wednesday, March 27, 2024. Strict security will be in effect at all other times.

SPACE ASSIGNMENT

Applications for exhibit space are subject to the approval of USCAP, in its sole discretion, not to be unreasonably withheld. A 500-character description (including spaces) of specific products and/or services must be keyed into the system at the time of submitting your online application form, even if you plan to alter it at a later date..

PRIORITY POINTS SYSTEM

Priority in space assignment will be accorded to previous Exhibitors on the basis of one point for each year of exhibiting, without regard to the number of booth spaces utilized. If more than one company has the same number of priority points, assignments will be made in date of receipt order.

Mergers: In the event that an exhibiting company merges with, is acquired by, or purchases another exhibiting company, the seniority accumulated by either company (whichever is highest) will be used. Exhibit Management must be notified in writing of such changes, including a public announcement of the transaction.

To take advantage of your point priority, applications and deposits must be received by November 17, 2023. Applications received after that time will be assigned space based upon date of receipt of application.

Platinum, Gold, and Silver Sponsors will receive priority placement in the Exhibit Hall.

BOOTH SELECTIONS

The floor plan ([CLICK HERE](#)) should be carefully reviewed and six exhibit preferences selected. Avoid concentrating all choices in one area. Indicate these choices on the online application for space. Because prime locations sell quickly, alternate acceptable booths should be indicated. If the selected booths are not available at the time the application is received, the Exhibitor agrees to accept the space assigned. Until the initial booth assignments have been completed (after the November 17, 2023, priority point deadline), all booths on the online floor plan will appear as "Available." From that point on, the Interactive Floor Plan will be live and will show assignments as they are made. USCAP reserves the right to modify the floor plan and reassign exhibit space if a change in the original assignment is necessary, as well as the right to final determination of booth location.

SHARING SPACE

No subletting or sharing of exhibit space is permitted without written consent from USCAP.

CO-MARKETING

If two or more companies wish to be assigned exhibit space adjacent to one another, all companies must attach a letter from each of the other companies, explaining the request and noting the request on each space application. Exhibit Management is not responsible for adjacent space assignment if space applications arrive separately or without documentation. The space assignment will then be made by averaging the co-marketing companies' points. Exhibit Management will locate adjacent exhibits based on the best use of the exhibit floor space, and requests for specific locations may not be honored.

If two or more divisions of the same company wish to exhibit together, they may exhibit under one company name. All housing, badges, and Exhibitor listings will be conducted in one name only.

Multiple housing blocks and listings are not permitted.

When two or more companies have joint rights to a product, and the contract stipulates all company names must appear with the product, USCAP reserves the sole right to determine how or if the name of the non-exhibiting company will appear on all exhibit-related materials. USCAP will make reasonable efforts to accommodate such requests after considering the facts and circumstances of the situation.

NON-CONTRACTED

Exhibit Space persons, companies, or organizations that have not contracted with USCAP to occupy space in the Exhibit Hall will not be permitted to display or demonstrate products, processes, or services; solicit orders; or distribute advertising materials in the Baltimore Convention Center, parking lots, or any hotel contracted by USCAP.

CHARGE FOR SPACE

COMMERCIAL INLINE BOOTH

(bounded by a front aisle only) is **\$3,300** (U.S.).
After November 17, 2023 - \$3,500 (U.S.)

COMMERCIAL CORNER BOOTH

(bounded by a front and side aisle) is **\$3,600** (U.S.)
After November 17, 2023 - \$3,800 (U.S.)

COMMERCIAL ISLAND BOOTH

(which may hang a sign over their booth and use full cubic content of their space.) is **\$4,200** (U.S.).
After November 17, 2023- \$4,400 (U.S.)

NONPROFIT INLINE OR CORNER BOOTH

is **\$2,200** (U.S.).
After November 17, 2023 - \$2,300 (U.S.)

Exhibits that are nonprofit according to the U.S. Internal Revenue Service Code will receive a discount, provided they submit a copy of their tax exempt certificate at the time of their application for exhibit space.

Important: A deposit of 50% of the estimated* cost (*based on estimate of commercial inline booth cost until after assignments are confirmed) for each booth requested is due along with each application. Nonprofit Exhibitors are required to submit full payment with their application. Exhibitors agree to pay the balance for the space assigned on or before Friday, February 23, 2024.

BOOTH SPACE CANCELLATIONS OR SPACE REDUCTIONS

To cancel or reduce space, Exhibitors are required to both:

1. Telephone Kristofer Herlitz, Exhibit Management at **845.243.2906** AND
2. Send a confirming letter of cancellation or space reduction to:

Kristofer Herlitz

The Herlitz Company
108 Montgomery St., Ste. 205
Rhinebeck, NY 12572-1106

The date the Exhibitor's written notice is received will be the official cancellation/reduction date.

Reduction of island space dimensions after assignment has been confirmed may result in relocation of the exhibit booth. USCAP may cancel Exhibitor rooms and room blocks held by a company canceling booth space.

IT IS AGREED THAT:

- a. As a reasonable calculation of liquidated damages for cancellation, and not as a penalty, it is agreed that: If a company cancels before December 22, 2023, an administrative fee of 25% of booth cost will be charged. If a company cancels its space between December 22, 2023, and January 25, 2024, it will be responsible for paying 50% of the total cost of the space.
- b. If a company cancels its space after January 25, 2024 it will be responsible for paying 100% of the originally contracted price.
- c. In the event the entire exhibit area is sold out, only an administrative fee of 25% of the canceled booth's cost will be charged, and the balance of monies received will be refunded.
- d. Space not claimed and occupied by 9:30 AM on Monday, March 25, 2024, will be forfeited by the Exhibitor, and the Exhibitor will pay as liquidated damages 100% of the total contracted booth space fee.

CANCELLATION OF MEETING AND EXHIBIT

It is mutually agreed that in the event the USCAP Exposition is canceled due to acts of God, war, strikes, government regulation or advisory (including travel advisory warnings by the government or World Health Organization), civil disturbance, terrorism, or threats of terrorism in Baltimore, as substantiated by governmental warnings or advisory notices, curtailment of transportation, epidemics, disaster, fire, earthquakes, hurricanes, unseasonable extreme inclement weather, shortages or disruption of the electrical power supply causing blackouts or rolling blackouts in Baltimore, or any other comparable conditions or circumstances that occur either in the location of USCAP's meeting or in the countries/ states of origin of at least thirty percent (30%) of the attendees or along their routes of travel, making it commercially impracticable, illegal, or impossible, the Application and Contract for exhibit space will be terminated. In such an event, the affected party shall not be liable to the other for delay or failure to perform its obligations, except there shall be a prorated reduction of any fees payable or otherwise due under this agreement and/or refund of any deposits paid. Transition to an online or virtual platform shall not be deemed to be cancellation of the Event. USCAP in its sole discretion may transition the Event to a virtual exhibition for health or safety considerations, in which case this Agreement (including without limitation fees and refund policy) shall continue in full force.

LIABILITY

Exhibitor assumes entire responsibility and hereby agrees to protect, indemnify, defend, save, and render the United States and Canadian Academy of Pathology, The Herlitz Company, the Baltimore Convention Center and Innovative Expo—to include employees and agents—harmless against all clam, losses, and damages to persons or property, governmental charges or fines, and attorney's fees arising out of or caused by Exhibitor's own installation, removal, maintenance, occupancy, or use of the exhibition premises or a part thereof, excluding any such liability caused by the sole negligence of the Baltimore Convention Center, Innovative Expo, The Herlitz Company, the United States and Canadian Academy of Pathology (USCAP), their employees and agents. In addition, Exhibitor acknowledges that the United States and Canadian Academy of Pathology, The Herlitz Company, the Baltimore Convention Center, and Innovative Expo do not maintain insurance covering Exhibitor's property and that it is the sole responsibility of Exhibitor to obtain liability, business interruption, and property damage insurance covering such losses by Exhibitor.

USCAP shall in no event be liable to an Exhibitor for any lost business opportunities or for any other type of direct or contract. It is understood and agreed that the sole liability of USCAP to the Exhibitor for any breach of this contract shall be for the refund of all amounts paid by the Exhibitor pursuant to this contract, as an exclusive remedy.

ENFORCEMENT OF RULES AND REGULATIONS

The Rules and Regulations of the United States and Canadian Academy of Pathology Exhibits are intended to bring order and fairness to the medium. In addition to being subject to restriction or termination of an exhibit (see General Character of Exhibits), Exhibitors who violate regulations will be subject to the following sanctions:

- 1ST VIOLATION:** Loss of current year priority point.
- 2ND VIOLATION:** Loss of one-half accrued points.
- 3RD VIOLATION:** Loss of remainder of points.
- 4TH VIOLATION:** One-year suspension of exhibit privilege.

Note: Exhibitors who dismantle before 4:00 PM, Wednesday, March 27, 2024, will be subject to a one-year suspension of exhibit privilege..

For major rule violations, which USCAP in its sole discretion will determine, a one-year suspension of exhibition privilege may be issued as a sanction. Also, USCAP reserves the right to refuse future applications for exhibit space, based upon prior, major rule infractions.

USE OF THE UNITED STATES & CANADIAN ACADEMY OF PATHOLOGY'S (USCAP) NAME, INSIGNIA, LOGO, OR ACRONYM (USCAP)

The use of USCAP's name, insignias, logos, and acronyms is expressly forbidden on signs inside and outside the exhibit area and on descriptive product literature and websites. References may be made to the meeting only as the "United States and Canadian Academy of Pathology's 113th Annual Meeting" on Exhibitor's advertising materials, provided that the specific use is first approved by USCAP in the precise manner in which the reference will appear. Place, names, and dates appearing with the reference will be acceptable. This policy applies before, after, and during the meeting. USCAP's name, insignias, logos, and acronyms are trademarks of USCAP and may not be used in any event without prior written permission.

SECURITY

Security for the exhibits will be provided, but the United States and Canadian Academy of Pathology, The Herlitz Company, the Baltimore Convention Center, and Innovative Expo do not guarantee to protect the Exhibitors against any loss or damage of any kind. Exhibitors are advised to be in their booths one-half hour prior to show opening each day.

PACKAGE REMOVAL POLICY

Deliveries or removal of equipment must be made before or after exhibit hours. A pass must be obtained from the Exhibit Management office to remove any material or equipment prior to Wednesday, March 27, 2024. Once the exhibit opens Wednesday morning for the last day of exhibiting, nothing may be removed until the exhibit is officially closed at 4:00 PM, at which time no pass is required. Security will not check equipment leaving the exhibit area after 4:00 PM, Wednesday, March 15, 2023. Strict security will be in effect at all other times.

INSURANCE

Exhibitors are urged to take out a portal-to-portal rider available at a nominal cost on their own insurance policy. This will protect them against loss through theft, fire, damage, etc. Exhibitors utilizing independent contractors must provide Kris Herlitz with a certificate of insurance of not less than U.S. \$1,000,000 by Friday, March 15, 2024.

EXHIBIT APPLICATION

To fill out the Exhibit Application: [CLICK HERE](#)

EXHIBIT SPACE

STANDARD BOOTHS

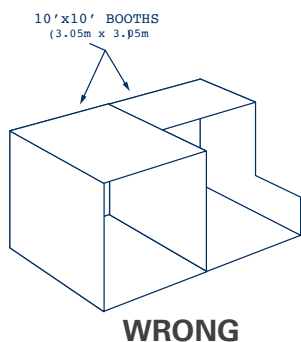
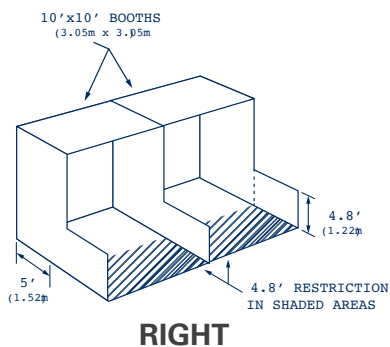

PENINSULA EXHIBITS

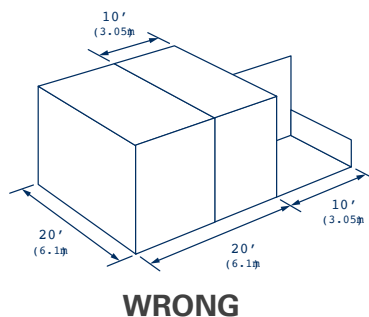
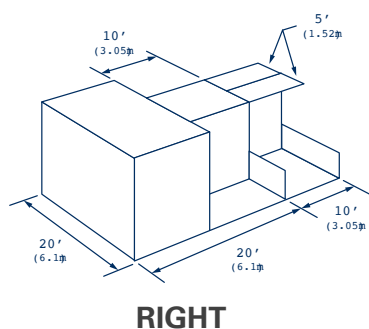

Each Exhibitor shall be responsible for compliance with the Americans with Disabilities Act within its booth and assigned exhibit space.

Each exhibit space will have an 8' high drape background, and 36" high drape dividers defining the sides of the space. Drapes will not be provided in island units. A booth identification sign measuring 7" x 44" and showing only Company Name, City, and State will also be supplied in all linear booths. Please note that the Exhibit Hall is not carpeted, so Exhibitors are required to order or provide carpeting in their own booth space—no booth may be without carpet.

Important: Standard inline and corner booths will be 10 ft. wide x 10 ft. deep (10' x 10'). The booth height of 8' may be maintained up to 50% of the distance from the back wall toward the front of the space. No obstructions in the front half of the booth above the height of 48 inches will be permitted. No exhibit may span an aisle by roofing or floor covering. Hanging signs and banners from the ceiling are permitted only over island booths, and the top of the sign may not be over the 18' height limit.

Nothing shall be posted, tacked, nailed, or otherwise attached to the walls, floors, or other parts of the exhibit facility or furniture contained in the facility. Exposed unfinished sides of exhibit backgrounds must be draped to present an attractive appearance. If such draping is not ordered, the decorator, with the approval of the Exhibit Management, will install draping and charge the Exhibitor.

In peninsula booth units, the peninsula should not cause a visual disadvantage to the adjacent exhibits that is greater than would be caused by an inline booth in the immediately adjacent space. Inline booth restrictions apply to the 10' portion of the exhibit that borders on another Exhibitor's booth; island specifications/restrictions apply to the remaining portion of the peninsula booth. Models or schematic drawings of cubic content exhibits should be submitted in advance to Exhibit Management for approval.

In island booth units, bound on four sides by aisles, the full cubic content of the space may be used; however, all display material is restricted to 20' in height, and the design of the booth must allow accessibility from all four aisles. Sufficient see-through areas must be provided so as not to block the view of the adjacent exhibits. Models or schematic drawings of cubic content exhibits should be submitted in advance to Exhibit Management for approval.

Note: Anything required to be submitted for approval to Exhibit Management in this section should be submitted prior to Friday, March 1, 2024

DEMONSTRATION AREAS

Demonstration areas may not be set on the aisle line of the exhibit; space must be left within the exhibit area to absorb the spectators. Should the spectators interfere with the normal traffic flow in the aisle or overflow into neighboring exhibits, the presentation must be limited or eliminated. Exhibitors are responsible for the safety (structural, fire, etc.) of their booths.

Note: Cybercafés (Internet access stations) are not permitted within a company's booth space

FLOOR PLAN

VIEW THE INTERACTIVE FLOOR PLAN – [CLICK HERE](#)

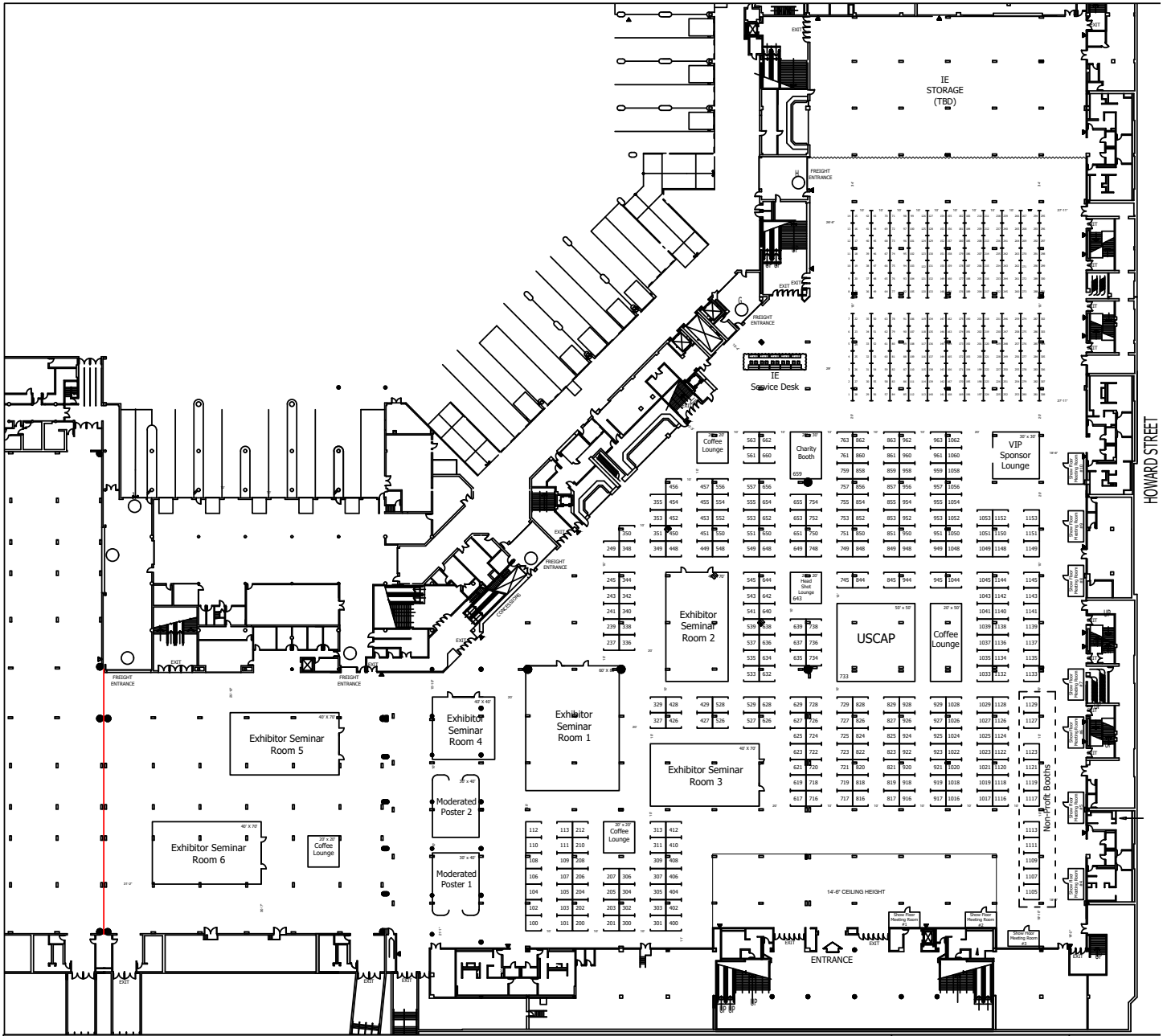

EXHIBITOR ADVISORY COMMITTEE

USCAP has an Exhibitor Advisory Committee (EAC). The purpose of the EAC is to provide a communication link between USCAP and its Exhibitors, specifically to:

- Review and comment on current and proposed Exhibitor Regulations;
- Review and comment on current and proposed practices affecting Exhibitors;
- Advise ways in which exposition could be improved, both from the Exhibitor's viewpoint and from the attendee's viewpoint;
- Identify additional information useful to Exhibitors; and
- Provide a forum for discussion of problems of mutual concern.

Members of the EAC each serve a five-year term. The committee meets once a year on Tuesday during the exposition. Exhibitors are encouraged to make their viewpoints and concerns known to USCAP and/or a Committee member. Exhibitor Advisory Committee members are as follows:

MEMBER SOCIETY REPRESENTATIVES

Adeboye O. Osunkoya, MD, President
Jason L. Hornick, MD, PhD, Vice President
Steven D. Billings, MD, President-Elect

Patrick Flaherty, Executive Vice President and Chief Executive Officer
Kristofer S. Herlitz, Exhibit Management

INDUSTRY REPRESENTATIVES

REAGENTS

Sara Saenz
Advanced Cell Diagnostics

INSTRUMENTS

Liz Hill
EpreDia

INFORMATION SYSTEMS

Doreen Eaton
NeoGenomics

PUBLICATIONS & EDUCATION PRODUCTS

Melanie Spain
Elsevier

LABORATORY SUPPLIES

Tom Pella
Ted Pella, Inc.

BOOTH ACTIVITIES & PERSONNEL

GENERAL CHARACTER OF EXHIBITS

In its sole discretion, at any time, USCAP may require modification of exhibits to bring them into compliance with this section and with the Rules. USCAP may, alternatively, require an Exhibitor to cease exhibiting if USCAP determines in good faith that no modification will suffice to correct harm done by Exhibitor's breach of the Rules.

The character of the exhibits is subject to approval by USCAP. USCAP reserves the right, even after an application is received, to refuse applications of concern not meeting standards required or expected, as well as the right to curtail or to close exhibits or parts of exhibits that reflect unfavorably on the character of the meeting. This applies to displays, literature, advertising, novelties, souvenirs, conduct of persons, etc.

Exhibitors are requested to staff their exhibits with personnel attired in a manner consistent with the decorum of the meeting, and knowledgeable in the products and policies of the company.

CONDITIONS OF CONTRACT

Exhibitors agree to abide by the contract conditions published in this prospectus and on the USCAP website and by all conditions stipulated by the Baltimore Convention Center that will be included in the Exhibitors Service Kit. Exhibitors accept responsibility for informing all of their employees and agents of these conditions and agree that they will abide by them as well.

LEAD RETRIEVAL SYSTEM

A rental lead retrieval system will be available to Exhibitors. All attendees will have a large, easy-to-read badge with their contact and demographic information encoded on the front of the badge. Attendee email addresses will only be included if the attendee selects this option when registering for the meeting.

Complete information will be included in the Exhibitor Service Kit that will be available in December 2023.

MESSAGES

Messages cannot be delivered to exhibit booths, nor is a paging system provided.

MODELS

USCAP expects Exhibitors to use prudent judgment when live models are used. Professional dignity and discretion should be observed at all times. The use of minors as live models is prohibited. Models contracted to assist with demonstrations in an Exhibitor's booth may not wear tight-fitting, exposing, or other inappropriate garments, such as leotards, T-backs, and short shorts.

PRINTED MATERIALS

Distribution of printed educational material by industry or its agents is limited to the area rented by the exhibiting company in the USCAP Exhibit Hall. These materials are not permitted in the registration area, poster session areas, meeting rooms, or corridors of the Baltimore Convention Center.

SELLING OF PRODUCTS OR SERVICES

Sales and order-taking are permitted provided that all transactions are conducted in a manner consistent with the professional nature of the exhibits. Exhibitors selling tangible goods must meet requirements of the City of Baltimore, MD's tax laws. Exhibitors are responsible for any and all licenses or permits required by law, as well as the payment of any taxes owed from sales.

Contests, lotteries, raffles, or games of chance, as well as the display or promotion of special discount offers, are prohibited.

DISTRIBUTION OF GIVEAWAYS

Giveaways will be limited to those items relevant to the professional interests of the registrants and will have a value of \$10.00 or less per item. Exhibitors may not sell, serve, or dispense any food on the exhibit floor. Disposable plastic bags will not be permitted as a give-away item. Reusable or paper bags are permitted. All giveaways and handouts, with the exception of literature, must have the written approval of Exhibit Management prior to the meeting. Such requests must be submitted to Exhibit Management by Friday, March 1, 2024. Requests received after Friday, March 1, 2024, will not be approved. USCAP will request removal of unapproved items.

MAILING LISTS

USCAP offers one-time rental of mailing lists including registrants from the Annual Meeting. These are strictly physical mailing addresses—no email addresses are permitted to be marketed by USCAP. Email addresses may be obtained by scanning registrants' badges when they visit your booth as long as registrants have opted to share their email address on their respective registration form.

The 2024 USCAP Annual Meeting pre-registrant list will be available after January 19, 2024, with a final registrant list available after April 15, 2024. Only 2024 USCAP Annual Meeting Exhibitors may rent the pre-registration list. Mailing list rental guidelines and order forms will be provided in the Exhibitor Service Kit. A copy of the proposed mailing piece must be submitted with the order form.

The mailing list(s) may not be used for any mailings other than that for which it is provided by USCAP, and may not be provided to any other party other than those to which permission was given.

In addition, Exhibitors are prohibited from selling and/or otherwise distributing demographic information obtained by swiping the name badges of attendees who visit their booth with lead retrieval devices. This information is restricted for use only by companies exhibiting at 2024 USCAP Annual Meeting, to send follow-up information requested by the attendee. Exhibitors violating these guidelines are subject to loss of all accrued priority points and/or a one-year suspension from exhibiting at the USCAP Annual Meeting.

EXHIBITOR REGISTRATION

Each exhibiting company will be entitled to six badges per booth space. Booth personnel may pre-register using the online exhibitor center. Exhibitors may pick up their badges at the Exhibitor Registration desk from 1:00 PM, Friday, March 22, 2024, throughout the meeting. To prevent delays, it is requested that all personnel changes be made prior to arrival in Baltimore, MD. Exhibitor badges must be worn at all times while in the exhibit area. Supplementing this identification with business cards, ribbons, or company logotypes is not permitted. Exhibitor badges may be made out only in the name of the company shown on the application for space.

COVID, HEALTH AND SAFETY

RIGHT OF ENTRY PROTOCOLS

USCAP has put measures in place to provide a safe environment for its event attendees. There is no vaccine requirement, however, it is recommended that all USCAP attendees, faculty, staff, and exhibitors are vaccinated against COVID-19. USCAP may change, update, or add to these requirements at any time it deems necessary to best protect the health and safety of attendees and others. Masks are not required but are encouraged.

ADMISSION TO SESSIONS

Badged exhibit personnel may attend scientific sessions that do not require a ticket on a first-come, first-served, space-available basis only, after scientific attendees have been seated. Overcrowding may subject a session to be shut down by the Fire Marshal. USCAP reserves the right to decline admission to any session in the interest of safety and comfort.

GUEST BADGES

Each exhibiting company will be entitled to six Guest of Exhibitor badges per booth space. These badges allow entrance to the Exhibit Hall during show hours only and may only be made out in the name of the exhibiting company requesting the Guest badge. Guests are considered anyone who is not an employee of that exhibiting company. Badges remain the property of USCAP and must be relinquished upon request from USCAP. USCAP reserves the right to limit the number of passes at any time.

Guest badges must be registered prior to arrival on-site by a representative of the exhibiting company and do not permit the bearer to attend the Annual Meeting scientific sessions.

WORK PASSES

All pre-approved Exhibitor-designated contractors must obtain work passes for all personnel at the Exhibitor registration desk. Work passes must be visible at all times while on the premises of the Convention Center. Work passes are valid during installation and dismantle only.

In the interest of safety, only those individuals directly responsible for the installation and the dismantling of the booth will be permitted in the Exhibit Hall during move-in and move-out times. Under no circumstances will children or guests be allowed within the exhibit area until the official opening of the exhibits at 9:30 AM, Monday, March 25, 2024.

TOBACCO POLICY

It is a policy of USCAP that the use of tobacco products, including smokeless tobacco, is strictly prohibited within all areas of the Baltimore Convention Center (including setup and dismantling of exhibits) and all hotel meeting rooms hosting USCAP events. Please inform all employees, agents, contractors, and guests accordingly. Thank you for not using any tobacco products.

PHOTOGRAPHY AT THE 2024 USCAP ANNUAL MEETING

Photography is permitted at the USCAP Annual Meeting within these boundaries: For personal use: Obtain consent from an individual before taking his or her picture.

Obtain consent from a vendor before taking a picture of his or her booth, employees, or products.

If you will utilize the photo for the express interest of promoting you or your company, be sure to obtain written consent from the appropriate entity before taking or publishing the photograph.

Bottom line: Please respect the individual or company's rights when taking photos and always have permission from the appropriate entity before taking or publishing a photograph.

HOUSING



onPeak has been designated as the Official Housing Bureau for the **2024 USCAP ANNUAL MEETING**. The Official Meeting hotels were chosen for the numerous benefits they offer meeting attendees and we request your assistance and support by booking your hotel accommodation at one of the Official Meeting hotels.

Accommodation reserved outside the Official Meeting hotel room blocks exposes the 2024 USCAP ANNUAL MEETING to financial penalties. Your loyalty and cooperation are greatly appreciated!

HOTEL SCAM ALERT

Please be aware that you may be contacted by companies or hotels claiming to be official 2024 USCAP Annual Meeting housing providers. USCAP will never contact you to solicit special offers. All lodging for USCAP should be arranged using the links provided or by calling the phone numbers listed here on the USCAP Annual Meeting page. Please **ONLY** provide your credit card information to official 2024 USCAP Annual Meeting hotels. Please notify USCAP as soon as possible, should one of these scammers contact you, by calling **760.327.6777** or emailing help@uscap.org. Please include "Housing Scam" in the subject line.

HOTEL RESERVATIONS

Official meeting hotels will not accept reservations directly. Reservations must be made online at onpeak.com/uscap or by calling onPeak at **1.800.220.4993** or **1.312.527.7300** (Int'l). The headquarters hotel for this meeting is the Hilton Baltimore Inner Harbor

[Click Here](#) to reserve your hotel room.

IMPORTANT INFORMATION

The deadline for reservations is **5:00 PM EST, Tuesday, March 5, 2024**. Requests received after this date will be forwarded direct to the specific official hotels.

All hotel prices are quoted in U.S. dollars, per night, per room. Rates are subject to an additional sales tax. Taxes are subject to change without notice.

If you have questions, please contact onPeak at the coordinates below:

2024 USCAP ANNUAL MEETING HOUSING

Toll-free #: 800.220.4993

International: 312.527.7300

Email: [OnPeak Contact Form](#)

PROHIBITED PROMOTIONAL PRACTICES

1. Giving away items that do not comply with stated policy
2. Subleasing exhibit space
3. Canvassing or distributing any material outside the Exhibitor's own space
4. Contests, lotteries, raffles, or games of chance, as well as the display or promotion of special discount offers
5. The wearing of buttons, unofficial badges, company name plates, etc.
6. Publicizing and/or maintaining any extracurricular activities, inducements, demonstrations, or displays away from the exhibit area during the dates of the meeting
7. Soliciting participation in surveys or otherwise harassing registrants
8. The use of any advertisements and/or displays of signs outside the exhibit space, as well as any advertisement within the exhibit space that does not comply with USCAP Rules
9. Entering another Exhibitor's booth or taking photographs of another Exhibitor's booth without permission
10. Operating X-ray equipment
11. Using noisy electrical or mechanical apparatus that interferes with other Exhibitors
12. Using of balloons or glitter products
13. Distributing or using stick-on decals and/or similar adhesive backed promotional items in the Baltimore Convention Center.

Relevant portions of the foregoing prohibited practices are applicable to non-Exhibitors at all times.

ENHANCED LISTING OPPORTUNITIES

See enclosed information including Product Listings and Enhanced Online Exhibitor Listings.

SOUND RESTRICTIONS

The use of open audio systems is discouraged. Requests to use an open audio system must be approved by Exhibit Management, and the Exhibitor must agree to discontinue its use if the sound level is deemed to be objectionable to registrants or adjacent Exhibitors. Noisy electrical or mechanical apparatus interfering with other Exhibitors is prohibited.

ELECTRICITY-AIR-WATER-DRAIN

These services will be provided by the Baltimore Convention Center. Order forms will be provided to each Exhibitor in the Service Kit.

Please send an email to kris@herlitz.com if water and drainage locations are required, because these locations are limited. All orders must be returned at least 21 days prior to the meeting dates.

FACILITY SPECIFICATIONS

INTERNET

Internet service must be ordered through the Baltimore Convention Center on forms which will be included in the Exhibitor Service Kit.

BOOTH CLEANING

Arrangements have been made to have each Exhibitor's booth floor cleaned the night prior to the opening of exhibits without charge. Any additional cleaning will be at the expense of the Exhibitor. Order forms will be provided in the Service Kit.

FLAMMABLE MATERIALS

No volatile or flammable fluids, substances, or materials of any nature prohibited by Baltimore's fire ordinances, the fire prevention bureau, or insurance carriers, may be used in any booth. The use of any type of crepe or corrugated paper is prohibited.

INSTALLATION & DISMANTLING

SERVICE DESK

A service desk will be open during installation to assist Exhibitors with verification and adjustments of their orders for labor, furniture, and other auxiliary services. The desk will also be staffed throughout the meeting.

EXHIBITOR SERVICE MANUAL

An Exhibitor Service Manual containing a complete set of service forms will be posted online by December 2023 and an email with the link will be sent to each exhibiting company. Exhibitors are urged to order all required services in advance.

INSTALLATION OF EXHIBITS

Friday, March 22: 1:00 PM – 4:00 PM

Saturday, March 23: 8:00 AM – 4:00 PM

Sunday, March 24: 8:00 AM – 4:00 PM

A labor crew will be available for the setup and dismantling of exhibits, in accordance with advance orders. Exhibitors are urged to order all services in advance. All exhibit material must be unpacked by 2:00 PM on Sunday, March 24, 2024. Any exhibit not unpacked at this time will be placed in storage and can be returned only after the exhibits close Monday, March 25, 2024 (the first day of exhibiting), or may be ordered set up by Exhibit Management and the cost charged to the Exhibitor.

Please Note: No refuse such as empty cartons may be placed in the aisles after the final sweeping in the exhibit area Sunday evening. Exhibitors are urged not to litter the floor in the booths or aisles after the final cleaning because time will not permit a sweeping of booths or aisles on opening day.

UNION REGULATIONS

MATERIAL HANDLING

Innovative Expo has the responsibility of receiving and handling all exhibit material and empty containers. It is Innovative Expo's responsibility to manage the docks and schedule vehicles for the smooth and efficient move-in and move-out of the exposition. Innovative Expo will not be responsible, however, for any material they do not handle. Teamsters Local claims jurisdiction over all unloading and reloading of freight, exhibit materials, product, and empty containers and related equipment. They also have jurisdiction over all material handling equipment including but not limited to forklifts, tow motors, dollies, pallet jacks etc. An exhibitor may hand-carry in one trip any material that does not require the use of wheels or other material moving devices. Hand carry is defined as small cartons, packages or portable laptop computers that usually weigh less than 30 pounds. Innovative Expo will not be responsible for any material that they do not handle.

BOOTH LABOR

The Decorators Local claims jurisdiction over setup and dismantling of exhibits including signs and laying of carpet. This does not apply to the unpacking and placement of your product. Any installation of exhibits or displays which requires the use of hand tools, more than one person, longer than 30 minutes to install (including crating or uncrating), or exceeds ten feet in any direction, shall be installed by employees covered by the agreement. Exhibitors may work in a single 10' x 10' booth without the aid of carpenter labor. The use of power tools by an exhibitor is not permitted in any situation.

SAFETY

Standing on chairs, tables, or other rental furniture is prohibited. This furniture is not engineered to support your standing weight. Innovative Expo cannot be responsible for injuries or falls caused by the improper use of this furniture. If assistance is required in the assembly/dismantle of your booth, please order labor in advance, using the forms that will be provided in the Exhibitor Service Kit.

FLOOR LOAD

The exhibit floor load of the Baltimore Convention Center is 350 lbs. per square foot. For heavy machinery or displays, contact Innovative Expo. Work lighting runs at 50 percent.

GRATUITIES

Innovative Expo requests that Exhibitors do not tip our employees. Do not give coffee breaks other than mid-morning and mid-afternoon when union employees have a fifteen-minute paid break. Any attempts to solicit a gratuity by an employee for any service should be reported immediately to a Innovative Expo supervisor. Employees of Innovative Expo are paid at an excellent wage scale denoting a professional status, and we feel that tipping is not necessary. This applies to all Innovative Expo employees.

CLEANING/JURISDICTION

Arrangements have been made through Innovative Expo to have each Exhibitor's booth floor cleaned Sunday night prior to the opening of exhibits, without charge. Exhibitors are allowed to maintain their exhibit space but are restricted to using their own company personnel. Any additional cleaning of exhibit space will be at the expense of the Exhibitor. Order forms will be provided in the Exhibitor Service Kit.

INDEPENDENT CONTRACTORS

Exhibitors who plan to use the services of anyone other than the official service contractor must notify Exhibit Management on or before Friday, March 8, 2024, in writing. Independent contractors must (1) perform services in accordance with Exhibition Rules and Regulations; (2) not solicit business on the exhibit floor; and (3) provide Exhibit Management with an original Certificate of Insurance of not less than U.S. \$1,000,000 by Friday, March 8, 2024, naming USCAP as additional insured.

FURNITURE-CARPETING-LABOR-RENTAL DISPLAY UNITS

The official convention decorator is:

Innovative Expo

Contact: Kathleen Smith

22375 Goldencrest Drive
Moreno Valley, CA 92553

Email: service@innovativeexpo.com

Phone: 760-343-2555

Fax: 760-343-2533

Forms will be sent to facilitate ordering furniture, labor, booth carpeting, and rental display units. Exhibitors are urged to order all furnishings and labor in advance to minimize delays during exhibit setup.

CURRENT LABOR RATES ARE:

Straight time - \$184/hr. 8:00 AM – 4:30 PM Monday – Friday except holidays

Overtime - \$334/hr. 4:30 PM – 8:00 AM Monday – Friday, Saturday, Sunday & holidays

DISMANTLING OF EXHIBITS

Wednesday, March 27, 4:00 PM – Midnight

Thursday, March 28, 8:00 AM – Noon

IMPORTANT INFORMATION: To avoid damage to your equipment or display, please remain with your exhibit until your crates are returned and your material is packed. USCAP, The Herlitz Company, Baltimore Convention Center and Innovative Expo cannot assume any responsibility for loss or damage to exhibits, equipment, personal belongings, etc.

SHIPPING

SHIPPING INSTRUCTIONS

All freight charges must be PREPAID.

It is recommended that all freight shipments be made on straight Bills of Lading, carefully prepared to show number of pieces and weight, 30 days in advance of installation of exhibits. A copy of each Bill of Lading should be forwarded to the official drayage company,

Innovative Expo

Contact: Kathleen Smith

22375 Goldencrest Drive Moreno Valley, CA 92553

Email: service@innovativeexpo.com

Phone: 760-343-2555

Fax: 760-343-2533

All shipments should be addressed as follows:

Advance Warehouse:

USCAP 113th Annual Meeting
Exhibiting Company Name/Booth Number

Innovative Expo/USCAP

c/o LibertyCFS

6720 Washington Blvd.

Elkridge, MD 21075

Direct to Show:

USCAP 113th Annual Meeting
Exhibiting Company Name/Booth Number

c/o Innovative Expo

Baltimore Convention Center

Halls D – G

One West Pratt Street

Baltimore, MD 21201

UNCRATED SHIPMENTS WILL NOT BE RECEIVED AT THE WAREHOUSE

The services provided by Innovative Expo will include receiving shipments at their warehouse and storing up to 30 days; delivery to the Exhibitor's booth; removal, storage, and return of empty crates and containers; and removal of packed shipments from the booth and reloading same on outgoing carriers from convention center or warehouse dock. Rates for this service are included in Exhibitor Service Kits. Exhibitors are urged to be certain that all materials are delivered to their booths on setup days because deliveries cannot be made during exhibit hours.

CRATE STORAGE

Empty crates, boxes, and cartons must be removed from the exhibit area by 2:00 PM, Sunday, March 27, 2024— the last day of exhibit installation. These materials should be nested as much as possible. "Empty" stickers, which must be placed on all containers to be stored and returned at the close of the exhibit, will be available at the exhibit service desk. Containers or skids without the "Empty" stickers will be considered refuse and disposed of accordingly. Crates, boxes, and cartons may not be stored behind booth backgrounds or under display tables.

Please note: Do not store anything of value in crates going into storage. Please address communications pertaining to exhibits to:

The Herlitz Company

108 Montgomery Street, Ste. 205

Rhinebeck, NY 12572-1106

Phone: 845.243.2906

Email: kris@herlitz.com

PRODUCT LISTINGS AND ENHANCED ONLINE EXHIBITOR LISTINGS



Exhibitors may choose a product category to be listed under so that attendees may find them by searching that category. Multiple category listings are available through enhanced online exhibitor listings outlined below.

PRODUCT CATEGORIES:

- | | |
|---|--|
| Artificial Intelligence (AI) | Medical Devices |
| Biomarkers | Non Profit Organization |
| Business Solutions | Pathology Testing Centers |
| Cell Analysis Systems | Pharmaceutical |
| Digital Microscopes and Scanners | Publications and Educational Products |
| Digital Pathology | Reagents |
| Image acquisition and analysis systems | Scanning Technologies |
| Image Management System | Software |
| Informatics | Tissue Marking Systems |
| Laboratories and Laboratory supplies | Tissue Processors |

PROMOTIONAL OPPORTUNITIES

INTERACTIVE EXHIBITOR FLOOR PLAN BANNER AD

Your ad is placed at the footer of the Interactive Floor Plan viewable not only on-site on the **Popular Exhibit Hall Locator Touchscreens** but in advance as attendees look at the online Interactive floor plan to map their on-site strategy.

Rotation: Random
Size: 205 wide x 60 high
Format: GIF/JPEG (non-animated)
Rate: **\$1,500 each**

PRINT EXHIBITOR LOCATOR BOARD SPONSORSHIP (limited to 1 company only)

Place your company logo on the large printed floor plans placed strategically throughout the Exhibit Hall, directing attendees as to the overall layout of the booths. Rate: **\$2,000**

INTERACTIVE FLOOR PLAN ON-SITE AND ONLINE LISTING PACKAGES

PACKAGE LEVEL UPGRADES		BASIC	TIER 3	TIER 2	TIER 1	
		Package Cost	FREE	\$1,000	\$1,500	\$2,000
Online Profile	Update your booth profile with all relevant company information. <i>Number of characters:</i>	500	750	1,000	1,000	
Welcome Message	Add an event-specific message highlighting your presence at the meeting.	Y	Y	Y	Y	
Videos	Let potential buyers see and hear your story through promotional videos.	N	N	1	2	
Product Categories	Select the categories potential customers are most likely to search to find your company.	1	5	5	10	
Products	Feature your latest product lines that will be introduced for the event or some of your most popular brands. Include descriptions and photos.	N	1	5	10	
Press Releases*	Highlight what's happening at your company. Tell your story in a printable, downloadable press release.	N	1	5	10	
Show Specials	Spotlight the deals—discounts, giveaways, post-show drawings, etc. —keep the traffic coming to your booth!	N	1	5	10	
Event Map Logo	Brand your presence on the show floor to make your company stand out above the rest of the competition.	N	Y	Y	Y	
Display Listing as Enhanced	Your online company listing will be noted with a red star further drawing the user to your listing vs. the others.	N	Y	Y	Y	

NEW PRODUCT DISPLAY

The New Product Display program provides USCAP members and attendees at the USCAP Annual Meeting with an effective way to identify new and innovative products at the show. It also provides you, the exhibitor, with a way to draw special attention to your new products or enhancements to existing products, including, but not limited to:

Products/Services just released from R&D

Products/Services enhancements

Products/Services launched since the 2023 USCAP Annual Meeting

Products/Services for research use only

Products/Services that have received FDA clearance or are pending FDA clearance

Products/Services for sale outside of the U.S.

Products/Services related to or for research and clinical laboratories

Don't miss this opportunity to help your products/services stand out from the hundreds on display at the USCAP 2024 ANNUAL MEETING

PROGRAM DESCRIPTION*

Poster display inside the convention center exhibit hall where all Annual Meeting attendees will see your product photos, product names, company name and booth number. **BONUS! – Product images from your New Product Display will be posted in the online Product Gallery that attendees access from the online Interactive Floor Plan!!**

**Applicable deadline must be met for products to be included in the display (see below).*

ANNUAL MEETING POSTER DISPLAY

The New Products Display will feature color poster boards located in a dedicated, high-traffic area of the exhibit hall. Each product display board (70" h x 36" w) will consist of photographs, the respective product names, a brief product description (maximum of 100 characters per photo including spaces), the company name, logo, and the booth number. Poster boards will be on display starting at 9:30 AM, Monday, March 25, 2024 and remain throughout the exhibit program. On-site corrections or adjustments may be possible if reported to Exhibit Management by Noon on Friday, March 22, 2024. No refunds or fee adjustments are available if corrections are reported after this time. Other changes and/or replacement may require additional charges.

DEADLINE FOR SUBMISSIONS

Friday, February 22, 2024

Completed applications (application form, fee, product description and final materials) received by this date are eligible for the on-site poster display. After this date we cannot guarantee eligibility but we will work for inclusion depending on when they are received. Contact **Kristofer Herlitz** (kris@herlitz.com) for more information.

ELIGIBILITY

The company must be an Exhibitor at the 2024 USCAP Annual Meeting.

The company must be the manufacturer or exclusive distributor of the product/service. The product/service must be represented in the exhibit on the show floor.

FEE

Base fee: **\$1,500**



NEW PRODUCT DISPLAY DIGITAL IMAGE SUBMISSIONS

POSTER REQUIREMENTS



One high resolution version of your new product display poster is required for each New Product Display application and poster production.

Submit your New Product Display image files by emailing the high resolution file(s) to kris@herlitz.com or placing in a Dropbox file.

Please follow the dimension and format specifications below. Submissions with New Product Display images that do not meet the digital poster requirements will not be produced.

HIGH RESOLUTION IMAGE: For Poster Display Resolution: **High**

Size: Final print size is a framed poster board measuring 70" high x 36" wide

Orientation: Vertical

Resolution: 300 dpi Color Mode: RGB only

File Format: JPEG only

File Naming: *yourproductname-hi.jpg*

Other: No rules or borders around poster, do not crop file too close to edge of poster size—please leave some space around it; there is a 6" footer that will block any image so actual poster size is 76" tall.

Note: Your JPEG should be at least 4 MB in size

MAILING ADDRESS:

Please send payment to:

The Herlitz Company
108 Montgomery Street, Ste. 205
Rhinebeck, NY 12572-1106

Submission of a logo instead of product photo will be accepted ONLY for products such as software and websites (subject to approval). Please contact **Kristofer Herlitz** if you have questions regarding your application, digital image submission, or need additional information at **845.243.2906** or via email at kris@herlitz.com.

SUBMISSION INSTRUCTIONS

Complete the New Product Display Application form. Use a separate form for each product/service submitted. Posters should describe only the named product/service.

- Prepare electronic files of the New Product Display image*
- Poster must be product-oriented (product portraits) and not promotional in nature
- Poster will be cropped to fit as necessary or may not be published if improperly formatted
- The file sent by Exhibitor should be in FINAL format (appear exactly as you wish the poster to appear).
The Herlitz Company producing the poster will incur additional fees that the Exhibitor is responsible for

**See above for instructions on digital file specifications.*

Order the New Product Display poster via the USCAP2024 Sponsorship Gallery and send completed application, materials, and check to **The Herlitz Company** by the deadline.

Incomplete submissions will be returned.

THE USCAP 2024 ANNUAL MEETING NEW PRODUCT DISPLAY APPLICATION FORM

Company:

Street:

City: Zip: Country:

Name & Title:

Phone:

Email:

Product Name: Introduction Date of Product:

Please refer to complete New Product Display submission requirements
MATERIALS DUE DEADLINE: FRIDAY, FEBRUARY 22, 2024

For poster images digital files can be supplied via email to kris@herlitz.com as a high resolution JPG file.

To apply for inclusion in the New Product Display, please sign, date, and email this insertion order back to kris@herlitz.com

Phone: 845.243.2906

Signed: _____ Date:

Final bills will be referenced with your PO# (if provided). You may pay online [here](#) or wait for your advertisement confirmation/invoice. All quoted rates are Net 30 days.

EXHIBIT FLOOR MEETING ROOMS

EXHIBIT FLOOR MEETING ROOMS

- USER GROUPS
- PEER TO PEER DEMOS
- HOT TOPICS
- MINI THEATRES
- FACE TO FACE PRIVATE MEETINGS

We have the option to purchase show floor meeting rooms where you are able to meet face-to-face with USCAP attendees in a private setting while maintaining the convenience of remaining on the Exhibit Floor at the Baltimore Convention Center.

These meeting rooms are available during Exhibit Hours. The modular room will have a lockable door, electricity, your company logo by the door, and will be carpeted. The exhibitor is responsible for any additional furnishings through the show decorator, Innovative Expo.

COST:

10'x 20' \$5,000 (ONLY 10 AVAILABLE!)

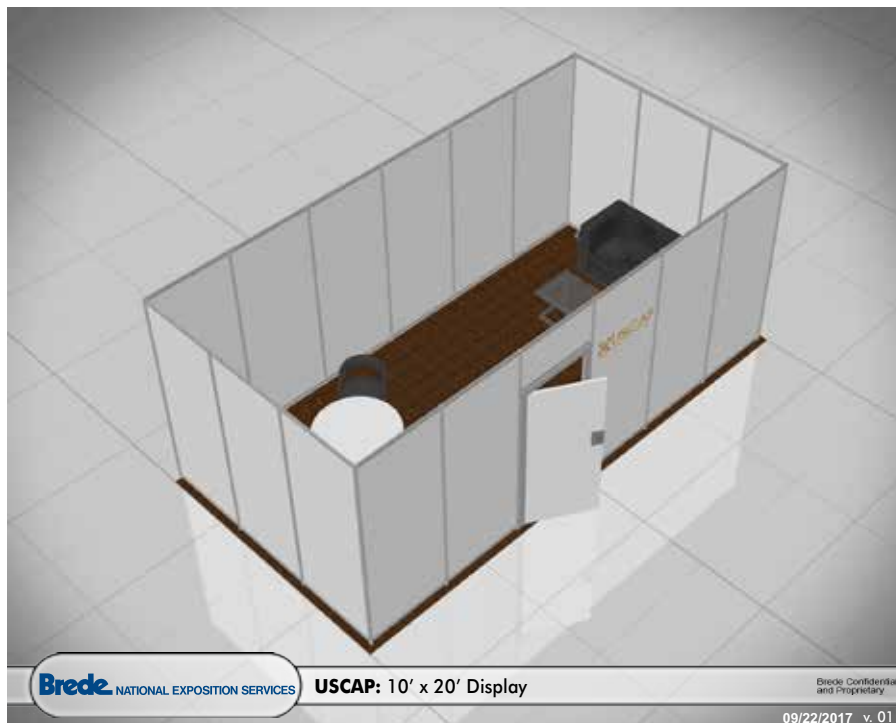

EXHIBITOR SEMINARS

Present your company's findings on USCAP's global stage. This unparalleled opportunity provides your organization an exclusive setting in which to present your latest research in an intimate setting that facilitates discussion—and relationships.

THESE EXHIBITOR SEMINAR ROOMS 2, 3, 5, AND 6 INCLUDE:

- A prominent meeting location on the Exhibit Floor
- Listing in Online Program (Exhibitor, date, time, topic, presenter(s), description)
- One Push Notification reminding of current day's Seminars
- One mailing list of the meeting's pre-registrants
- A complete audiovisual package, including 7'6" x 13'4" Truss Frame Screen, a 11000 Lumen DLP Projector, one computer and one podium with microphone
- Opportunity to capture contact data on all your Seminar attendees

Total cost: \$12,500

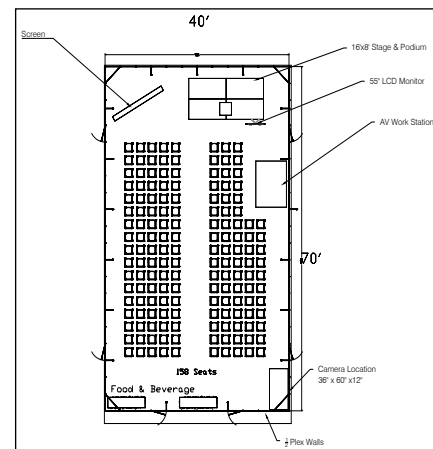

Add \$5,000 for Recording in Exhibitor Seminar Rooms 1, 3, 6

BE A PART OF THE VIRTUAL USCAP 2024 ANNUAL MEETING HELD AFTER THE IN-PERSON MEETING AND PRESERVE YOUR PRESENTATION – RECORD IT!!

- Recording of entire session that you can repurpose for your own company content and post your Exhibitor Seminar to your company website.
- Widen and track your audience by having your Exhibitor Seminar posted to the On Demand content of the USCAP 2023 virtual meeting held the week after the in-person annual meeting.

***IN EXHIBITOR SEMINAR ROOM 3 ONLY, for an additional \$2,500 (\$7,500 total) to have your Exhibitor Seminar live-streamed on the USCAP platform.**

LIVE STREAMING & RECORDING FROM EXHIBITOR SEMINAR ROOM 1!!

- Widen your Audience and **Broadcast your Presentation** from the Oversized Exhibitor Seminar Room 1 to the USCAP limited live-streamed sessions on the virtual Platform. Then be placed within the On Demand content for the Virtual USCAP 2024 annual meeting being held the week after the in-person annual meeting! Includes full A/V set-up, extra seating for up to 200, and additional room for F&B.
- Recording of entire session that you can repurpose for your own company content.
- Listing in Online Program (Exhibitor, date, time, topic, presenter(s), description)
- One Push Notification reminding of current day's Seminars
- One mailing list of the meeting's pre-registrants
- Opportunity to capture contact data on all your Seminar attendees
- A complete audiovisual package, including large dual screens, a 11000 Lumen DLP Projector, one computer, speaker set-up, stage, podium, microphone, and soundboard!

Total cost: \$20,000

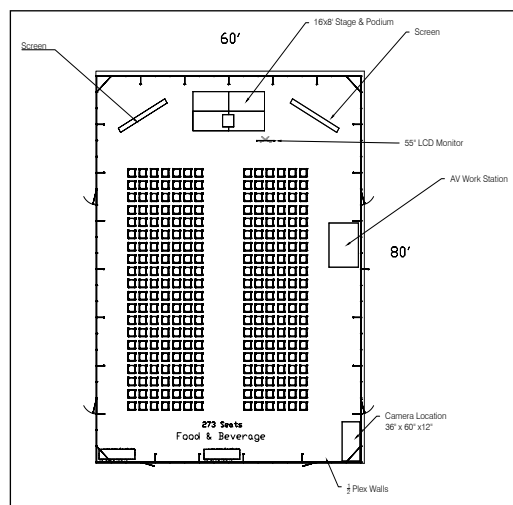

EXHIBITOR SEMINAR ROOM 4

Never tried an Exhibitor Seminar at USCAP before? Testing out new topic/session content? Consolidate your Audience in a Smaller Exhibitor Seminar Room 4 - designed as a more intimate setting. No recording or live streaming is available in this room.

- A prominent meeting location on the Exhibit Floor
- Listing in Online Program (Exhibitor, date, time, topic, presenter(s), description)
- One Push Notification reminding of current day's Seminars
- One mailing list of the meeting's pre-registrants
- A complete audiovisual package, including 80" video monitor, 2 speakers, one computer and one podium with microphone
- Opportunity to capture contact data on all your Seminar attendees

Total cost: \$7,500

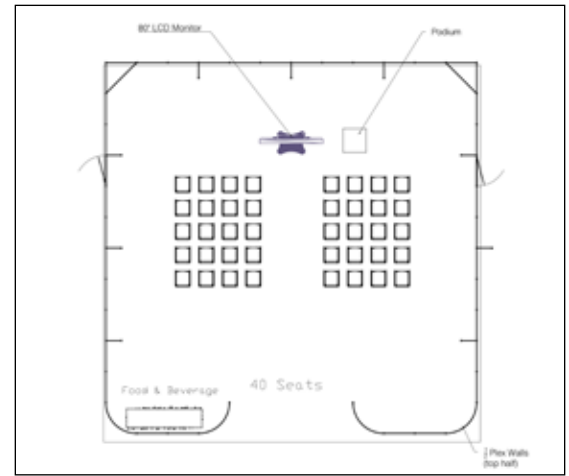

THE USCAP 2024 ANNUAL MEETING EXHIBITOR SEMINAR APPLICATION, PAYMENT AND CANCELLATION POLICY

USCAP is offering a limited number of exhibitor seminar opportunities to qualified exhibitors. A seminar summary, speaker list, completed application and 50% deposit must be submitted together. The USCAP will review and approve all seminar proposals prior to the room assignments. The 50% deposit will be held pending approval of the seminar. Should the seminar not be approved, the full deposit will be returned. Please see the “exhibitor rules and regulations” for participation prior to completing the application. Space will be assigned on a first come-first served basis after approval has been granted. Deadline for application and seminar summary is February 2, 2024, but advance submission is recommended.

You must be an exhibitor and approved by USCAP to hold a seminar.

CANCELLATION POLICY AND FEES:

1. Cancellations should be communicated to Kristofer Herlitz at The Herlitz Company by phone AND with a confirming cancellation letter to:
2. Cancellations will be based on the following schedule:
3. Until February 2, 2024, all commitments may be canceled in full, less a 20% administration fee based on the payments received to date.
4. Following the schedule of payments, any payments made after February 2, 2024, will not be refunded.

The Herlitz Company
108 Montgomery Street, Ste. 205
Rhinebeck, NY 12572-1106
Phone: 845.243.2906
Email: kris@herlitz.com

SCHEDULE OF PAYMENTS:

1. This completed Exhibitor Seminar form and all payments should be sent to **Kris Herlitz** at the address listed above.
2. 50% must accompany the Exhibitor Seminar Form.
3. Balance due by February 2, 2024.

PAYMENTS:

Pay Online at Exhibitor Portal [here](#)

Call Exhibit Management at **845.243.2906**

THE USCAP 2024 ANNUAL MEETING EXHIBITOR SEMINAR RULES AND REGULATIONS

1. In order to hold an Exhibitor Seminar at our Annual Meeting the following rules and regulations must be adhered to:
2. You must be an exhibitor in our exhibit hall (any booth size). For Exhibitor information contact: **Kristofer Herlitz** at **845.243.2906** or Email: kris@herlitz.com or go to www.uscap.org and look under the "Annual Meeting" link.
 - a. The cost to reserve space for an exhibitor seminar is \$12,500. Payment in the form of check, credit card, money order, ACH or wire transfer is to be made in advance at the time of invoice to:
The Herlitz Company
Attn: Exhibitor Seminar/Kris Herlitz
108 Montgomery Street, Ste. 205
Rhinebeck, NY 12572-1106
3. A brief overview of the presentation and listing of speakers (with full contact information) must be submitted to the USCAP office by no later than February 2, 2024.
4. Demonstrations and/or displays of commercial products and/or literature will not be permitted at exhibitor seminars. Distributing commercial products and product literature will be prohibited at exhibitor seminars as well. Exhibitor seminar speakers may refer to a product as a reference tool during their presentations; however, a complete demonstration or display of the product is not permitted.
5. The time scheduled for your seminar cannot be in competition with any of our scientific meetings and is scheduled at the discretion of USCAP on a first come, first served basis depending on room availability.
The hours are: Monday, Tuesday, Wednesday 12:00 pm-1:00 pm or 5:30 pm-7:00 pm (**with no evening session scheduled for Wednesday**).
6. USCAP will place your Seminar on the online meeting Program, Meeting App and on scrolling monitors with other meeting content. Also, you may purchase an ad in either Modern Pathology or Laboratory Investigation. For more information about advertising in these USCAP journals contact:
Jim Secretario – US Sales Director (US and Canada)
Phone: 917.678.0541 E-mail: j.secretario@elsevier.com
Robert Bayliss – Head of Sales Europe (EU Territory and ROW)
Phone: + 44 20 7424 4454 E-mail: r.bayliss@elsevier.com
7. All promotional/advertising materials must be submitted to the USCAP office for approval prior to distribution.
8. Signage for your meeting must be provided by you and its display is limited to one sign only immediately outside the entrance door to your meeting room. Any signage found in any other location will be discarded. You may use this sign in your booth prior to the session to advertise your meeting.
9. Room drop advertisements are not permitted.
10. CME credits are not permitted to be given for these activities.
11. You will receive a complimentary room assigned by USCAP in the Baltimore Convention Center. Space is limited and is available on a first come, first served basis.
12. You will receive complimentary Audio-Visual equipment limited to a 7'6" x 13'4" fast-fold screen (or smaller) LCD projector (80" monitor with 2 speakers for ESR #4), one computer, one podium with microphone. Any additional items or upgrades will be the responsibility of the exhibitor.
13. You will receive one complimentary physical mailing list (no e-mails addresses) of pre-registrants for the purpose of advertisement per exhibitor rules. You may request this any time before the meeting.
14. The responsibility of upgrades for Audio Visual, catering needs, change of room setup, etc. will be between the Exhibitor and the various suppliers. USCAP is not liable for any deviations from the standard package offered.

THE USCAP 2024 ANNUAL MEETING EXHIBITOR SEMINAR RULES AND REGULATIONS

For more information on exhibitor seminars, contact
Kristofer Herlitz at kris@herlitz.com

On behalf of my organization, I have read the above Rules and Regulations and I agree to the terms set
before me:

Company:

Representative Name & Title:

Representative Signature: _____ Date: _____

GENERAL INFORMATION:

In order to become an official 2024 USCAP Exhibitor Seminar Sponsor, you first must become an Exhibitor. The 2024 Exhibition Hall is the place to meet pathology's decision makers and early adopters. Centrally located, the Exhibition Hall opens to our guests on March 25, 2024 and runs through March 27, 2024, giving you a full three days to meet the pathology community one-on-one.

For more information, contact the Exhibition Hall Manager, **Kristofer Herlitz** at **845.243.2906** or kris@herlitz.com.

JOIN PATHOLOGY'S GLOBAL EVENT THIS YEAR AND EVERY YEAR



BOSTON

MARCH 22 – 27, 2025
BOSTON CONVENTION CENTER
BOSTON, MA

SAN ANTONIO

MARCH 21 - 26, 2026
HENRY B. GONZALEZ CONVENTION CENTER
SAN ANTONIO, TX

VANCOUVER

MARCH 13-18, 2027
VANCOUVER CONVENTION CENTRE
VANCOUVER, B.C. CANADA

